



# PRO-SOUND CEILING LOUDSPEAKERS

CCS6 CCS6/T

## Installation instructions

1. Cut a hole in the ceiling 230mm diameter

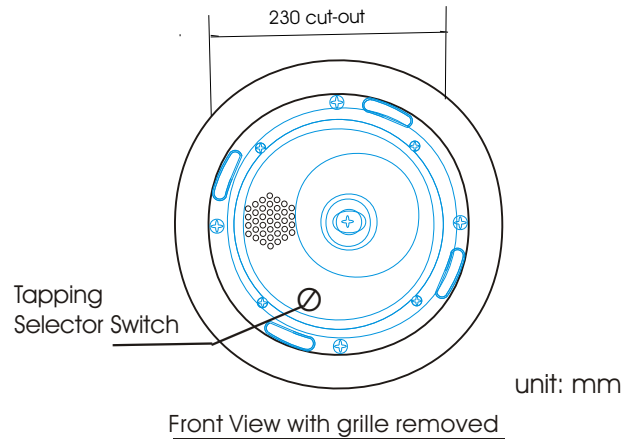
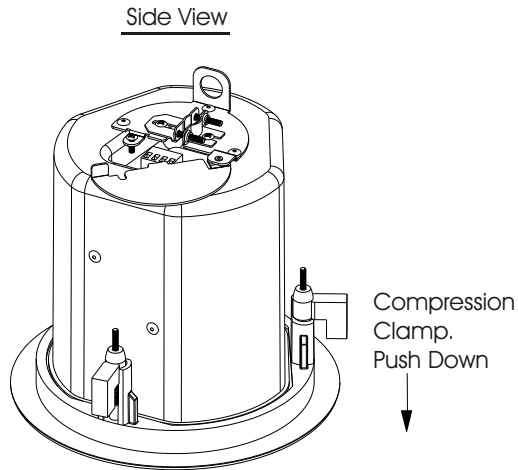

2. Remove the metal grille from the front of the loudspeaker by pushing all the rotary compression clamps down towards the grille

3. Once the grille has been removed connect the 100 volt line input cable via the terminal block secured under the rotating cover shown below "A". To select the required wattage output use the tapping selector switch shown in the above drawing

This unit is also available in low impedance (16 ohms) Model CCS6 and will be connected as above ( the unit will be manufactured minus the 100 volt line transformer)

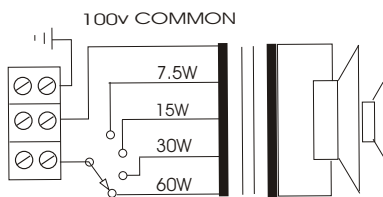

Circuit Diagram

CCS6/T

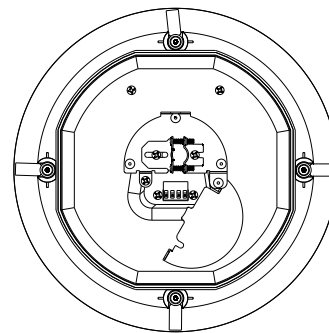

Rear View

4. The loudspeaker is ready to be pushed up into the cutout prepared earlier. Ensure that all compression clamps are fully extended to allow for the ceiling thickness. Once the loudspeaker is in position use a cross headed screwdriver and turning it in a clockwise motion you will observe that the clamps will pull down and lock the loudspeaker into position. A mounting bridge baffle is available for thin ceilings as an optional extra.

5. On mounting the speaker replace the snap fit grille.