

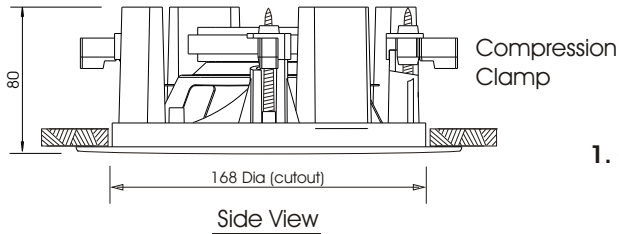

# ROUND PLASTIC CEILING LOUDSPEAKER

PCL5/T

## Installation instructions



1. Cut a hole in the ceiling 168mm diameter

2. Remove the metal grille from the front of the loudspeaker by pushing all the rotary compression clamps down towards the grille

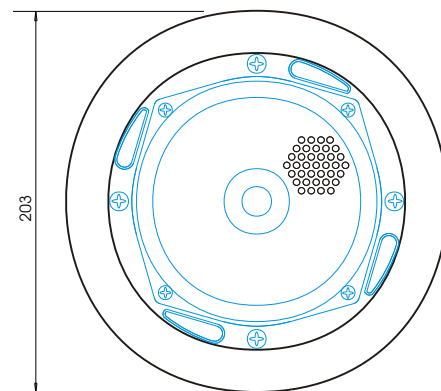
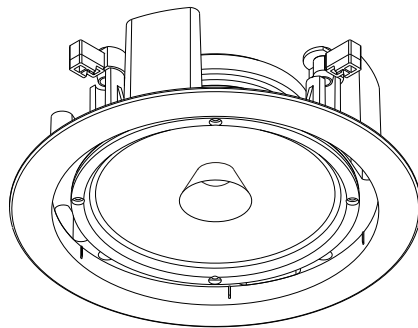

unit: mm

Front View with grille removed

3. Once the grille has been removed connect the 100 volt line input cable to the required tapping via the terminal block shown in the circuit diagram.

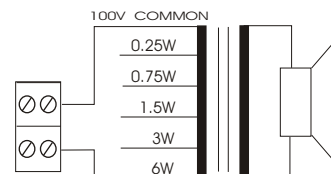

Circuit Diagram

4. The loudspeaker is ready to be pushed up into the cutout prepared earlier. Ensure that all compression clamps are fully extended to allow for the ceiling thickness. Once the loudspeaker is in position use a cross headed screwdriver and turning it in a clockwise motion you will observe that the clamps will pull down and lock the loudspeaker into position.

5. On mounting the speaker replace the snap fit grille.