



WEATHERPROOF HORN LOUDSPEAKER

PH20/T

PH20/TC

Installation instructions

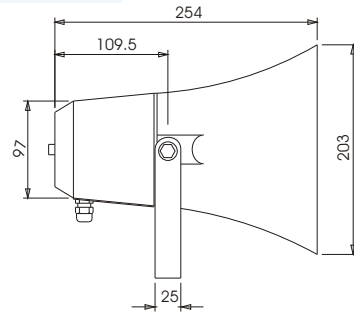

unit: mm

Side View

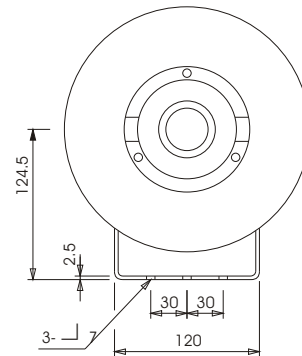

Front View

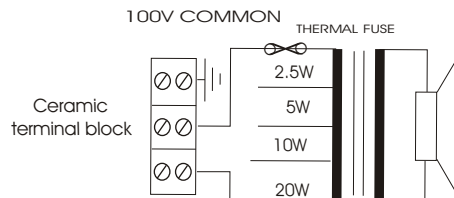

PH20/TC Circuit diagram

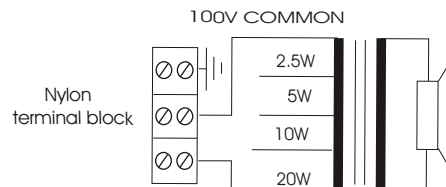

PH20/T Circuit diagram

1. Remove the back lid of the unit and connect input cable to the ceramic terminal block through the cable gland provided.
 2. On removing the back lid of the horn you will observe a 3 way ceramic or 5 way plastic terminal block that is connected to the 100 volt line transformer, fit the input cable. To select the wattage tapping required look at the top of the transformer, you will find a selection of taps from 20 watts down to 2.5 watts. To change the tapping move the female spade connector (white) located on the transformer to the appropriate male spade terminal
- The white lead also contains a thermal fuse for circuit protection in the advent of a fire
3. On selecting the tapping required and wiring the same, secure the cable gland tight into the back lid of the chamber.
 4. Around the inner section of the chamber where the back lid was removed a rubber gasket is located; please make sure that it is in-place when re-fitting the back lid to avoid water penetration.
- There is a fibreglass sleeve covering the central mounting bolt, it is important that this cover is used, it is used to protect the transformer.
5. Drill the mounting location holes for the unit in line with the "U" bracket (2 holes 60 mm apart) in the surface where the loudspeaker is to be located. It is not necessary to use the central mounting hole in the bracket unless the loudspeaker is located on a pole mount clamp.
 6. Mount the speaker in the required location specified by an acoustic engineer.
 7. Before putting 100 volt line through the unit it is advisable to check the impedance of the circuit
 8. On checking that the line impedance is to your requirements, the speaker will be operational.